

# 80A06 PatternSync Trigger Module Instructions

www.tektronix.com



## Safety Summary

To avoid potential hazards, use this product only as specified.

While using this product, you may need to access other parts of the system. Read the *General Safety Summary* in other system manuals for warnings and cautions related to operating the system.

### To avoid fire or personal injury

**Ground the product.** This product is indirectly grounded through the grounding conductor of the mainframe power cord. To avoid electric shock, the grounding conductor must be connected to earth ground. Before making connections to the input or output terminals of the product, ensure that the product is properly grounded.

**Observe all terminal ratings.** To avoid fire or shock hazard, observe all ratings and markings on the product. Consult the host instrument documentation for further ratings information before making connections to the host instrument.

Do not apply a potential to any terminal, including the common terminal, that exceeds the maximum rating of that terminal.

**Do not operate with suspected failures.** If you suspect there is damage to this product, have it inspected by qualified service personnel.

**Do not operate in wet/damp conditions.**

**Do not operate in an explosive atmosphere.**

**Keep product surfaces clean and dry.**

## Safety Terms In This Manual

**CAUTION.** Caution statements identify conditions or practices that could result in damage to the equipment or other property.

### Safety symbols on the product



## Environmental Considerations

### Product End-of-Life Handling

Observe the following guidelines when recycling an instrument or component:

**Equipment Recycling.** This product complies with the European Union's requirements according to Directive 2002/96/EC on waste electrical and electronic equipment (WEEE). For information about recycling options, check the Support/Service section of the Tektronix Web site ([www.tektronix.com](http://www.tektronix.com)).

### Restriction of Hazardous Substances

This product has been classified as Monitoring and Control equipment, and is outside the scope of the 2002/95/EC RoHS Directive. This product is known to contain lead and hexavalent chromium.

## Product Description

The 80A06 PatternSync Trigger module requires the 8000 series product software version 2.4 or later. This module extends the triggering capabilities of the mainframes listed in the Specifications table in this document by providing a frame synchronous (pattern) trigger. The pattern trigger can be created from any data-related clock, such as a recovered clock signal, a user-supplied clock, a sub-clock, or super-clock. This module can also be used with the 82A04 Phase Reference Module to provide down to 200 fs<sub>rms</sub> timebase jitter.

The 80A06 module supports the use of the 80SJNB Advanced Jitter, Noise and BER Analysis Software. Standard acquisition and Framescan are also supported.

The 80A06 module is programmable from the mainframe user interface or the GPIB interface.

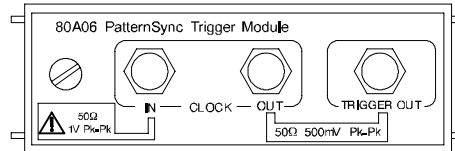

Figure 1: 80A06 PatternSync module

## Installing and Removing the Module

This module installs directly into any small module slot in the listed mainframes. See the mainframe documentation for proper installation and removal of modules.

**CAUTION.** Instrument modules are extremely static sensitive. Always ground yourself when handling modules.

## Connector Care

Use extra care when attaching or removing SMA connectors. Turn only the nut, not the cable. Align the connectors carefully before turning the nut. Use light finger pressure to make the initial connection. Then tighten the nut lightly with a wrench. Ideally, the SMA connectors should be tightened to 56 N-cm (5 in-lb) with a torque wrench.

## Operation

When using this module with 80SJNB Advanced Jitter, Noise and BER Analysis Software, use a Phase Reference module installed in your mainframe to ensure the most accurate measurements.

The 80A06 accepts a user-supplied clock signal and divides it by a programmed amount to generate a frame trigger at the 80A06 TRIGGER OUT connector. The trigger signal is not routed internally and should be routed to the TRIGGER DIRECT INPUT connector of the mainframe.

The trigger user interface of the mainframe allows you to program the module to divide the input clock signal by an integral multiple of the length of the repetitive frame being applied to the device under test (DUT), generating a frame-synchronous trigger output.

The 80A06 module also provides a buffered copy of the input clock at the CLOCK OUT connector. This signal can be used for clocking other equipment or as the phase reference clock input for the 82A04 Phase Reference Module.

## Specifications

### Electrical

Characteristic	Specification
Mainframe interface	Tekprobe®-Sampling, Level 3. Hot switching is permitted.
Applicable mainframes	DSA8200, TDS8000, CSA8000, TDS8000B, CSA8000B, TDS8200, CSA8200
Number of channels	One
Input and output connectors	SMA female
Input/output impedance	50 Ω
Maximum non-destruct range	2.5 V <sub>pk-pk</sub>
Maximum operating range	2.0 V <sub>pk-pk</sub>
Maximum DC offset	± 5.0 VDC
Input electrical return loss	>15 dB 150 MHz to 10 GHz >10 dB 10 GHz to 20 GHz
Input/output coupling	CLOCK IN AC CLOCK OUT AC TRIGGER OUT DC, ground referenced
Supported clock rates	Minimum 150 MHz Maximum 12.5 GHz 12.75 GHz (typical)
Input clock prescaler ratios <sup>1</sup>	>150 MHz to ≤ 3.5 GHz 4 >3.5 GHz to ≤ 7 GHz 8 >7 GHz to ≤ 12.75 GHz 16

Electrical (continued)	
Characteristic	Specification
Programmable pattern length <sup>1,2</sup>	
Minimum	2
Maximum	2 <sup>23</sup> (8,388,608)
Front panel output amplitudes	
CLOCK OUT (50 Ω, AC coupled)	
150 MHz to 8.0 GHz	500 mV <sub>pk-pk</sub> (typical)
8.0 GHz to 12.75 GHz	250 mV <sub>pk-pk</sub> (typical)
TRIGGER OUT (50 Ω, DC coupled, ground referenced)	
Output high level	0 V
Output low level	-550 mV (typical)
Front panel output rise and fall times	
CLOCK OUT	<60 ps (typical)
TRIGGER OUT	<60 ps (typical)
System trigger jitter generation	
DSA8200, CSA/TDS8000B, CSA/TDS8200	
Input clock >1.2 GHz	<1.3 ps <sub>rms</sub> 850 fs <sub>rms</sub> (typical)
Input clock ≤1.2 GHz	<3 mUI <sub>rms</sub> 1.5 mUI <sub>rms</sub> (typical)
DSA8200 & CSA/TDS8000	
Input clock >1.2 GHz	<1.6 ps <sub>rms</sub> 1.0 ps <sub>rms</sub> (typical)
Input clock ≤1.2 GHz	<3 mUI <sub>rms</sub> 1.5 mUI <sub>rms</sub> (typical)
DSA8200 & CSA/TDS8200 with 80A06 and 82A04 modules	<200 fs <sub>rms</sub> (typical)
Minimum input sensitivity	
150 MHz to 8.0 GHz	100 mV <sub>pk-pk</sub> 50 mV <sub>pk-pk</sub> (typical)
8.0 GHz to 12.75 GHz	200 mV <sub>pk-pk</sub> 50 mV <sub>pk-pk</sub> (typical)

<sup>1</sup> DSA8200, CSA/TDS8000, CSA/TDS8000B, and CSA/TDS8200 mainframe user interface or GPIB configuration.

<sup>2</sup> The 80A06 is programmed to within the hardware range of the module (a pre-scaler followed by a counter with a minimum count of 30) for the least-common-multiple count.

Environmental and Mechanical	
Characteristic	Specification
Weight	0.4 kg (0.6 lbs)
Dimensions	
Height	25 mm (1.0 in)
Width	79 mm (3.1 in)
Depth	135 mm (5.3 in)
Environmental conditions	Refer to the host instrument specifications
Electromagnetic compatibility	Refer to the host instrument specifications

## Setup Diagrams

The following illustrations show typical setup configurations that use the 80A06 PatternSync Module with other module types installed in a mainframe.

### Differential data setup

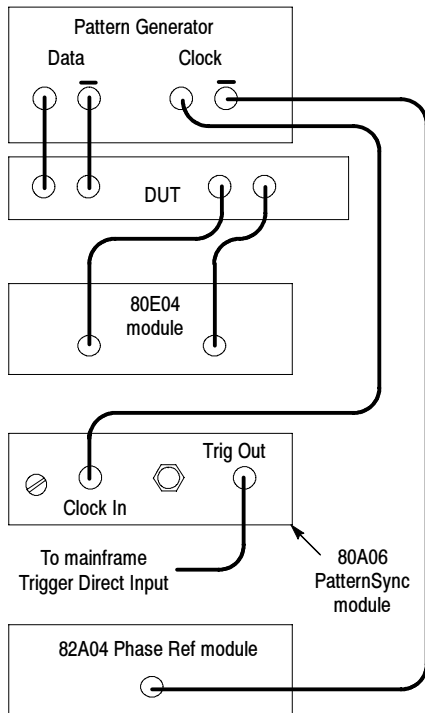

### Optical data setup

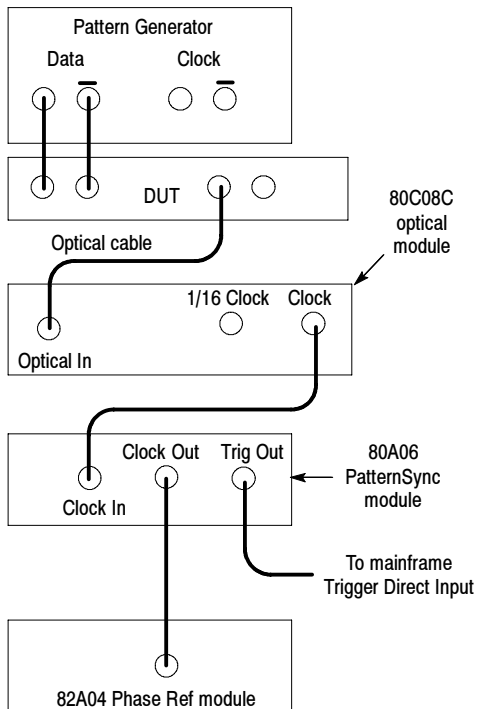

### Clock recovery setup

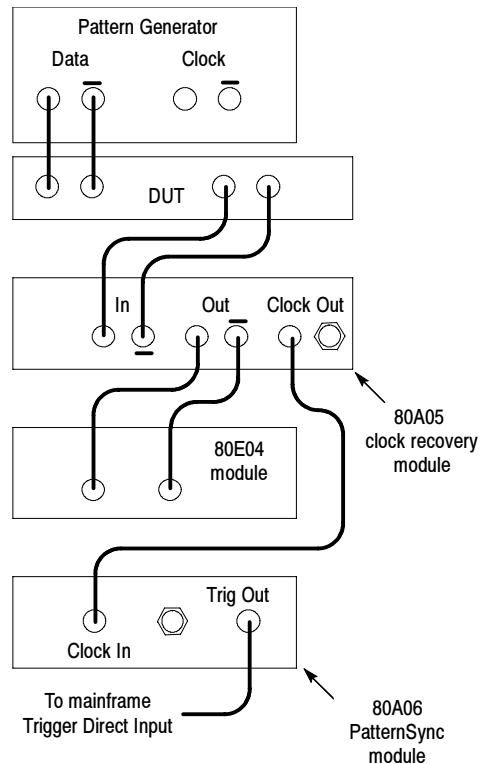

### Accessories

The following accessories are shipped with the 80A06 PatternSync Trigger module:

- 80A06 Instructions 071-1744-xx
- 8000 Series Product Documentation CD-ROM 020-2543-xx
- (2) 12 inch SMA cables 174-1364-xx

### Functional Check

Use the following procedure to verify that the 80A06 PatternSync module is recognized by the host mainframe.

1. After installing the module, power on the mainframe and wait for the scope application to fully boot.
2. Select the Utilities menu and then select System Properties.
3. Click the Modules tab.
4. Click the + next to the channel number where the 80A06 module is installed.
5. Verify that the module nomenclature and serial number are listed.

### Warranty Information

For warranty information, go to [www.tektronix.com](http://www.tektronix.com), click Support, and then select Look Up Tektronix Warranty.